



# OWNER'S MANUAL



**CDL'S SELF CLEANING FILTER PRESS**

Thank you for choosing a CDL filter press. Our 40 years of experience working with sugarmakers ensures you that you acquired a performant and quality piece of equipment. Before using this product, make sure you understand all the following instructions. If there is any problem upon reception of this product, please immediately contact CDL or your local representative.

## FINDING INFORMATION

### Make a record for future use

Brand: \_\_\_\_\_

Purchased Date: \_\_\_\_\_

Model Number: \_\_\_\_\_

Serial Number: \_\_\_\_\_

### Serial number location

The serial number is located on the support frame



# TABLE OF CONTENT

Finding information	2
Table of content	3
Safety	3
Description	4
Information about the filter	5
Installation	6
Valve and connection	7
Filtration	10
Removing the sweet	11
Cleaning	12
Filteraid	14
Filtering capacity	17
Maintenance	17
Troubleshooting	17
Warranty	18
Parts	20

## SAFETY

A filter press can be a dangerous piece of equipment. It processes very hot maple syrup, so when it is in operation, the plates gets very hot. Make sure that no one touches the press. Also, before operating, inspect every hose to make sure they are in good condition, especially the one between the pump and the plates because it's the one that sustains the highest pressure.

If you have to replace any hose, make sure it is strong enough to take a temperature of at least 230<sup>0</sup> F and a pressure of 200 psi.

Finally, always watch the pressure gauge of the press. If the pressure get over 50 psi, it means that it's time to clean the press. If you don't, there is a chance that a hose might either burst or pull out of it's fitting, splashing hot syrup all over the place. If it happens, anybody near may suffer severe burns.



## **FILTER PRESS DESCRIPTION** (drawing 1)

A filter press is a piece of equipment made to filter liquids. This CDL press is primarily used to filter maple syrup, but it can also filter all kinds of liquids as wine, honey or beer. The plates are made of cast aluminum, providing lightweight and good heat conductivity. It is essential to filter maple syrup to get a better tasting product, free of impurities.

**Rear plate:** The rear plate is fixed to the frame of the press. The syrup inlet and the outlet are located on this plate

**Filter paper:** You must insert one filter paper between each plates of the press. These papers do the filtering of the maple syrup. We recommend 2 papers between each plate in case of a paper tear.

**Hollow plates:** When assembling the press, you must always alternate between a full plate and a hollow plate. These hollow plates allow the syrup in the press and they keep the filtering residues and the filter powder in the press.

**Full plates:** These plates give the syrup access to the outlet of the press. The small holes in these plates must stay unplugged or the syrup will not leave the press.

**Front plate:** This plate must be installed after an empty frame and tighten in place using 2 nuts.

**NOTE:** The thickness of the hollow plates is important. The thicker the plates, the more filter powder they can hold, the longer you will be able to run between filter paper change.



## **IMPORTANT INFORMATION FOR THE RECEIVED FILTERS WITH SELF-CLEANING PRESS CDL.**

**FILTERS (F200-0025-1 / 2-C-MD-PD6A AND F200-0025-1 / 2-RD-MD-PD6A) MUST BE INSTALLED AS IS DRAWING BELOW TO FILTERED AIR INJECTED IN THE PRESS WHEN WASHING. THESE ARE THE FILTERS FOR REMOVING OIL PARTICLES AND SMELL THAT MAY LEAK FROM THE AIR COMPRESSOR. IF THE INDICATOR ON TOP CHANGED TO RED YOU WILL NEED TO CHANGE THE FILTER ELEMENT INSIDE. YOU WILL ONLY NEED TO UNSCREW THE LOWER PART TO ACCESS THE FILTER. AIR SHOULD GO FIRST BY F200-0025-1 / 2-C-MD-PD6A AND THEN IN F200-0025-1 / 2-RD-MD-PD6A. FILTER ELEMENT (663458 AND 663459). ARE AVAILABLE IN CDL STORE.**

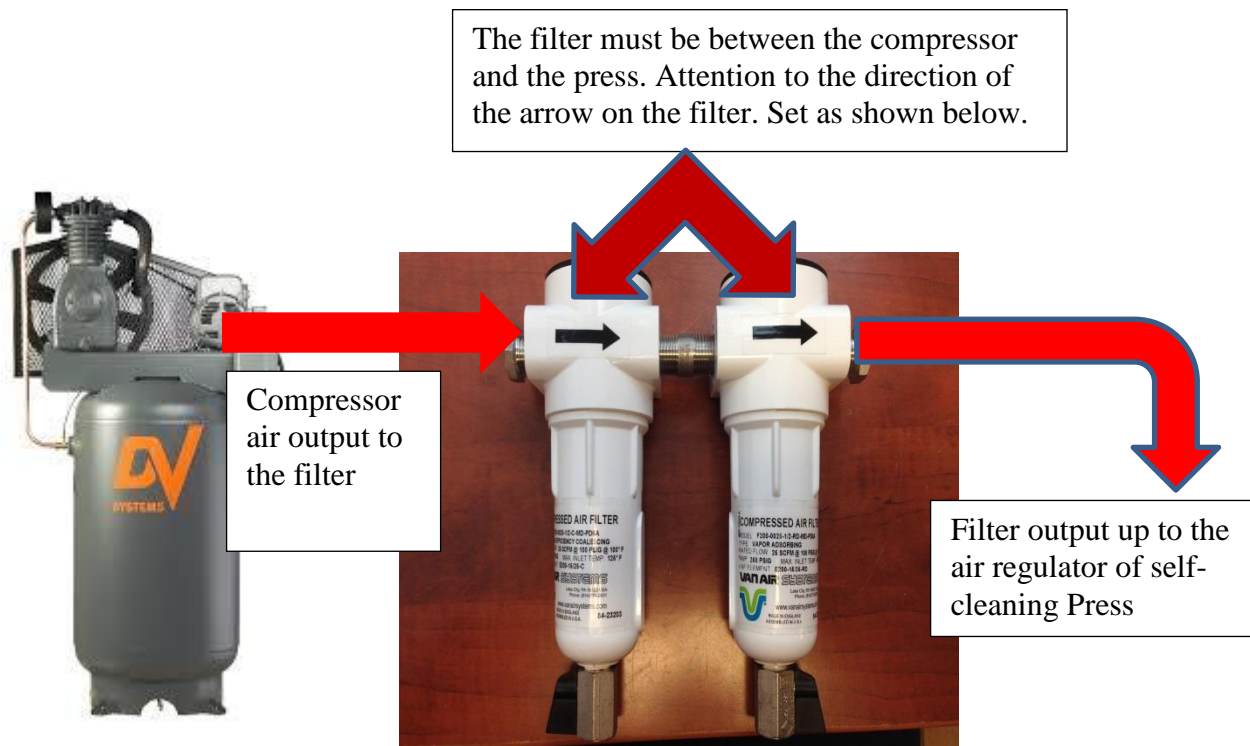

**A food grade type of oil should be used for the lubrication of your compressor. Check with a dealer in air compressors.**



# INSTALLATION

**Air compressor, 3hp minimum or more.  
60 gallon tank.  
Minimum capacity 13-15 cfm at 45 psi**

**Permeate tank, minimum capacity  
of 500 gallons with an outlet of at  
least 2" diameter.  
It can be your permeate tank if it's  
big enough.**



**2" or bigger pipe diameter.  
Install a valve to control the flow.  
Connect to the 4" clear pipe coming out of  
the press.**



**Hook up the  
compressed air  
to the press**

**Connect to a drain.  
At least 3" diameter.**

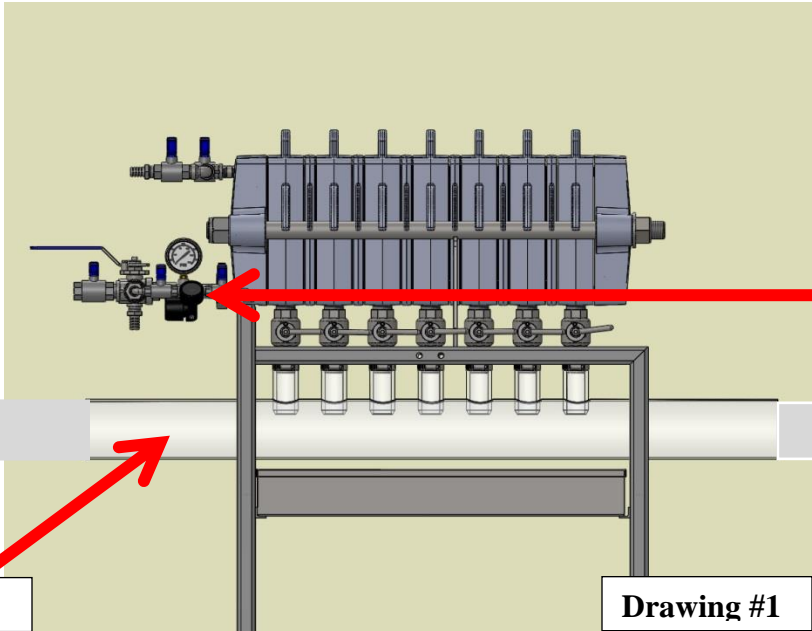

**4" clear pipe**

**Drawing #1**



# VALVES AND CONNECTIONS

Bypass valve used to heat the press or to fill it initially.  
**(THIS VALVE MUST BE CLOSED WHEN FILTERING AND CLEANING THE PRESS)**

Maple syrup outlet control valve.

The first valve is used to bring the syrup towards your recipient and the other to send the sugared cleaning water to the sap tank or the evaporator.  
**(THOSE VALVES MUST BE CLOSED WHEN CLEANING)**

Pressure gauge  
**(NEVER GO ABOVE 50 PSI)**

Optional outlet and control valve to control an air diaphragm pump.  
**(THIS VALVE MUST BE CLOSED IF NOT USED)**

3 way control valve  
-select: syrup  
Or  
-select: hot water and air for cleaning

Syrup in from the pump.

Drawing #2

Hot water control valve for cleaning.  
Hook up the hot water source here.

Air control valve for cleaning.

Compressed air from the compressor.  
Connexion 1/4" (ajustment 45 psi)  
Hook up the air from the compressor here.



## ASSEMBLY OF THE PRESS

**WARNING : IF THE PRESSURE IS TOO HIGH, THE AIR CAN CAUSE A HOSE TO BURST AND CAUSE INJURY. NEVER EXCEED 50 PSI.**

1-Make sure the plates are clean.

2-Install all the hollow plates by inserting the drain tube in the 4" clear tube located under the press. **Make sure the guiding markers are aligned together.** For an easy installation, dip the drain tube in hot water for 1 minute. (See drawings #3 and #5)

3-Instal the full plates, making sure the guiding markers are lined up. (See drawing #3)

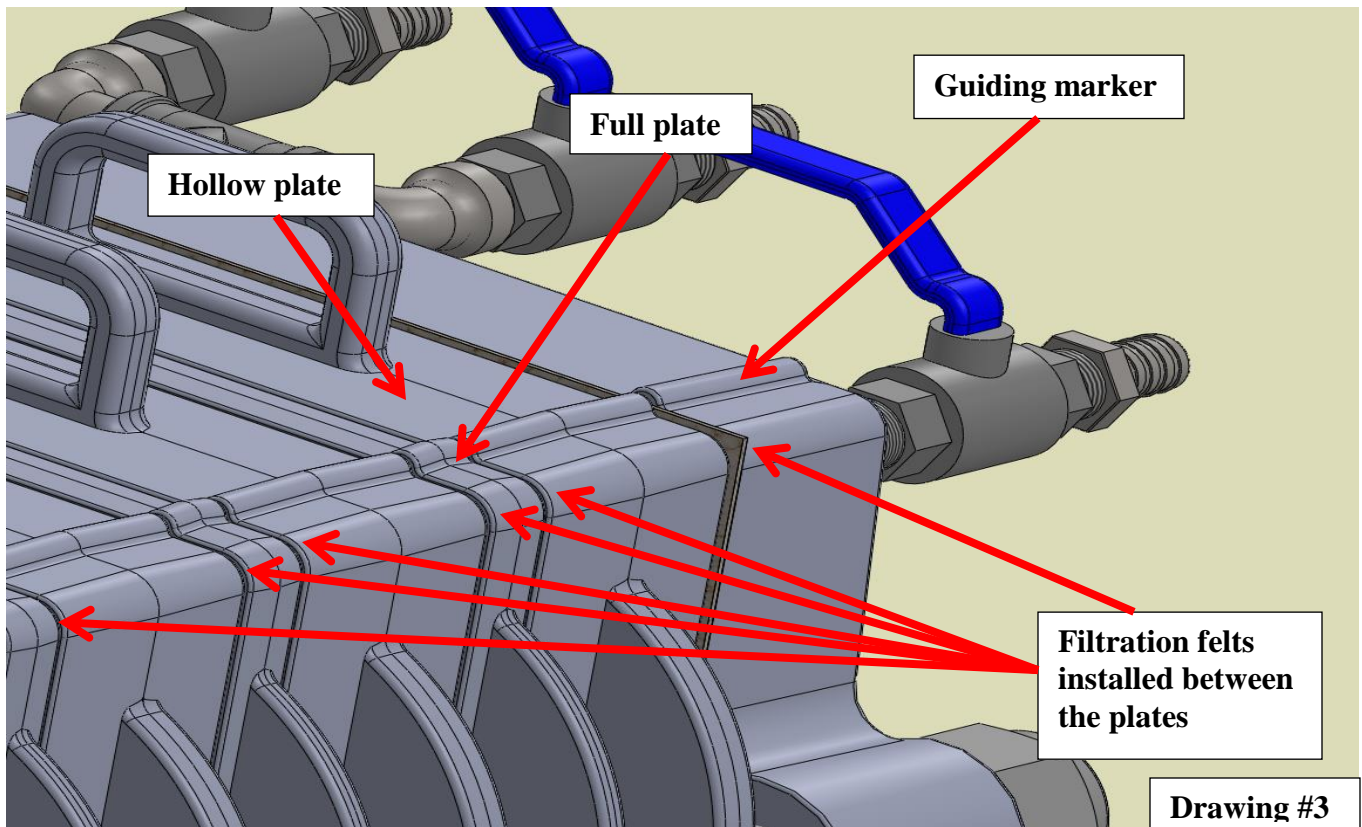

4- Insert the CDL "JET" filtration felts between each plates. The felts have a hole in each corner. Install the felts straight as shown in drawing #2. Use caution, it is a delicate operation, the holes in each corner must be aligned with the holes in the plates.





5-Instal the end plate and leave enough play to insert a felt between the last hollow plate and the end plate.

6-Insert a filtration felt between the last hollow plate and the end plate.

7-Hold the felt in place and push the end plate to squeeze in the felt. Be carefull not to pinch your fingers.

8-Now that the felt is maintained in place by the end plate, let it go.

9-Insert the washers and tighten the bolts on the rods.

**Note :** You might have to retighten the nuts when the press gets hotter to reduce leaks between the plates. Be carefull not to overtighten, when the felts are new they may let a little syrup drip down but it will improve as the felts get more syrup through them.

**Tightning washers and nuts.**

**Use the right wrench. Never extend the wrench, you don't want to overtighten the plates.**

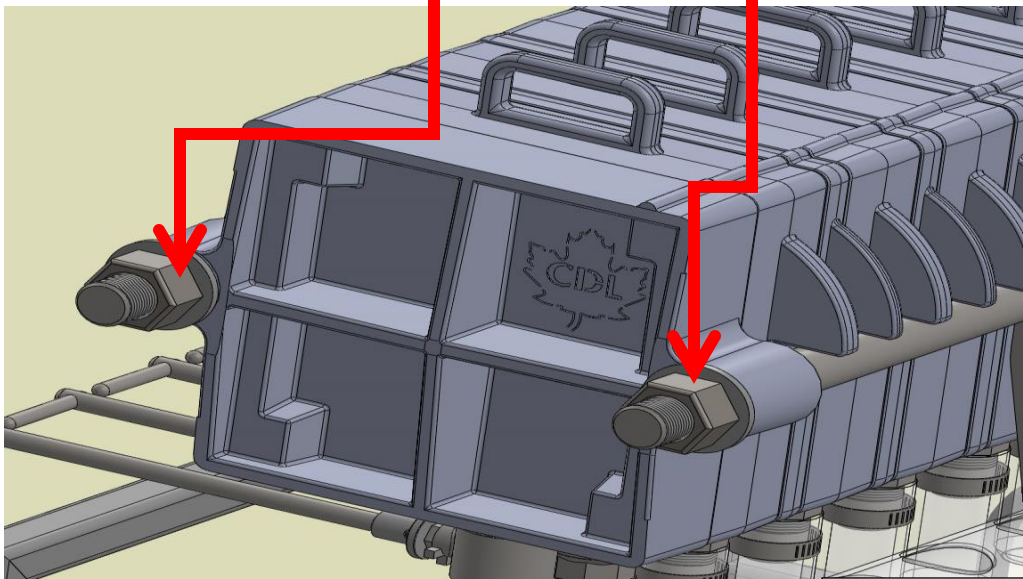

**Drawing #4**

10-Your press is now ready to filter maple syrup.

**Note :** The press can stay assembled permanently. However, we recommend an inspection of the felts every 75 barrels (3000 gallons).



## FILTRATION OF MAPLE SYRUP

1-Prepare a mixture of filter powder and 3 to 4 gallons of hot maple syrup directly in your draw off tank.

2-Make sure the powder is perfectly mixed with the syrup.

3-Make sure the press is properly assembled and ready to filter.

4-Open the press feed valve from the draw off tank to the press feed pump.

5-Make sure all the drain valves under each hollow plates are closed (see drawing #5).

6-Turn the 3-way valve toward the maple syrup feed line.

7-Make sure the cleaning air valves are closed.

8-Make sure the bypass valve is closed.

9-Make sure the hot water feed valve is closed.

10-Open the syrup outlet valve (going to the barrel).

11-Take the outlet hose and put it in the draw off tank, creating a closed circuit.

12-Start the syrup feed pump.

13-Let the syrup circulate for 2 to 3 minutes, then verify if the syrup coming out of the press is clear.

14-When the syrup is clear, the press is ready to filter syrup. Take the outlet hose and put it in a barrel or any container you choose.

**Note : When the filtration pressure reaches between 40 and 45 psi, start the cleaning process.**



## REMOVING THE SWEETS AFTER YOU ARE DONE FILTERING

1-Turn the 3-way valve to feed the feed pump with hot water.

2-Change the valve setting so that the water coming out of the press goes to either the sap tank or the evaporator.

**YOU MUST HAVE AT LEAST A 4 X 14 EVAPORATOR TO BE ABLE TO SEND THE HOT WATER TO THE EVAPORATOR.**

3-Start the feed pump and wait for the sugar content to go down to close to zero. Test with a refractometer if desired.

4-You are ready to start the cleaning process.



# CLEANING

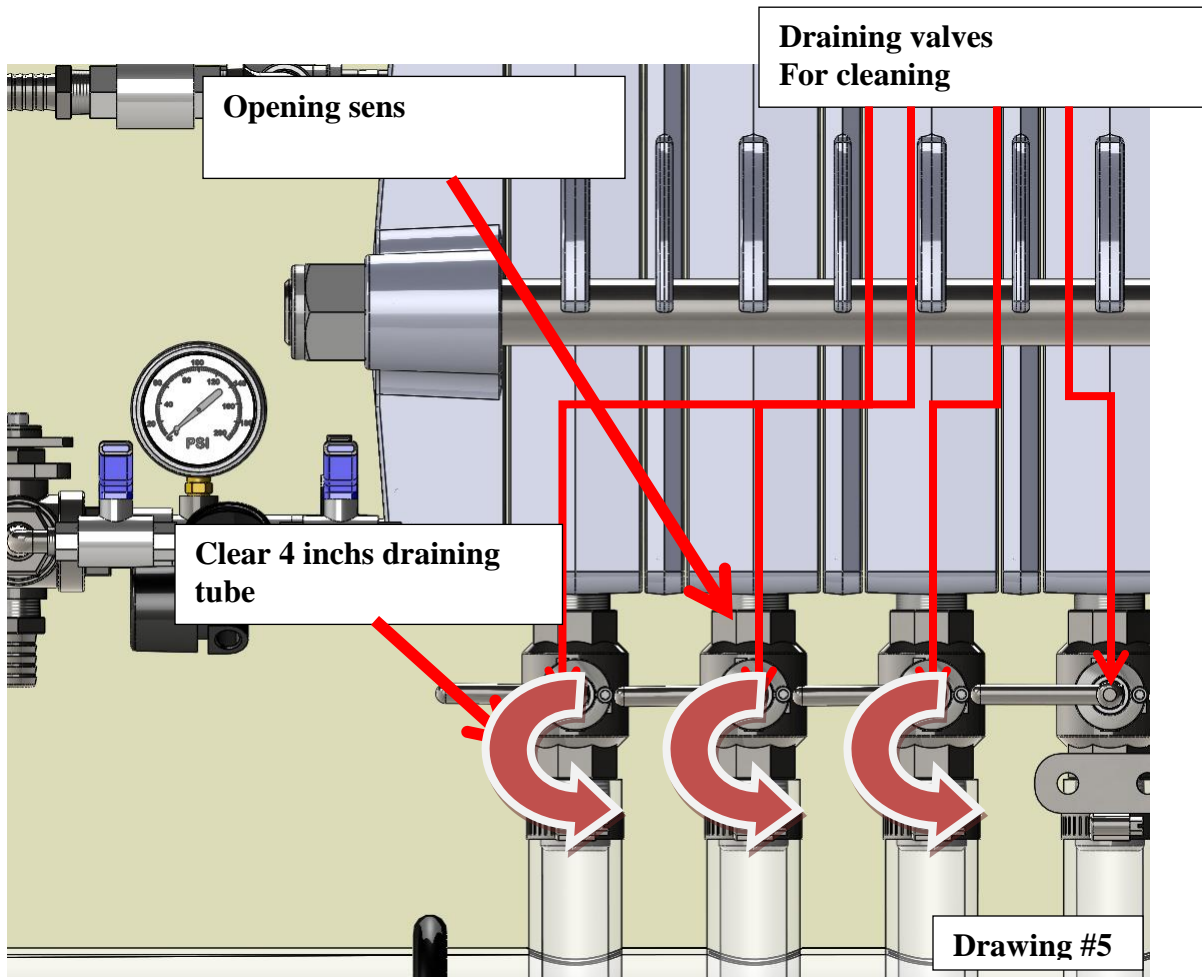

Note: Refer to drawings #1 and #2 to locate the right valves.

1-Open the permeate feed line (large clear pipe) filtra. (Voir schéma d'installation) (IMPORTANT : The permeate must circulate and fill at least half of the 4" pipe to make sure not to plug the drains).

2-Make sure the air regulator is set at a pressure of 45 psi or less.

3-Close the 2 syrup outlet valves.

4-Set the 3 way valve to the wash position.

5-Open the cleaning air control valve.

6-Open the cleaning hot water control valve.



7-When the pressure gauge reaches 45 psi, open only the first hollow plate drain valve. Wait until the pressure comes back to zero. The water coming out of the drain will turn clear.

**Note :** At this stage, it is normal that air and water make their way out of the filters, especially when they are new. The felt will become more and more leak free as the felts get older and filters more syrup.

8-Close the first drain valve and wait for the pressure to come back to 45 psi.

9-Repeat operations 8 and 9 for each hollow plate.

10-When done, close the air control valve.

11-Close the hot water control valve.

12- Open every drain valves under the hollow plates.

13-Wait for all the hollow plates to drain and close all the drain valves.

14- Close the permeate feed valve.

15-Turn the 3-way feed valve to syrup.

16- Ouvrir the syrup outlet valve.

17-The press is clean and ready to filter maple syrup again.

**WARNING: IF THE PRESSURE IS SET TOO HIGH DURING THE WASH CYCLE, IT COULD BURST OPEN A HOSE AND CAUSE INJURIES. NEVER GO ABOVE 50 PSI.**



## USE OF FILTERAID

In general, diatomite (diatomaceous earth) has a more intricate particle shape and thus provides a more tortuous path for suspended particles to be trapped. Because filtering is basically a surface trapping phenomena (over simplified) and thus one always strives to use a filter aid that has a median pore size (the opening of the tortuous channels) just slightly smaller than the average particle size of the suspended matter that you are trying to remove. Diatomaceous Earth has many grades to select from for the specific application.

Diatomaceous Earth (also known as DE, diatomite and Kieselghur) is the fossil remains of plankton that died in the oceans millions of years ago and sank to the bottom to form deposits. Chemically it is predominantly silica, one of the most abundant minerals on the upper crust of our planet, earth! It's odorless, non-toxic and foodgrade.

### FILTRATION "THEORY"

Filtration using diatomite is a two step operation. First, a thin protective layer of filter aid, called the precoat, is built up on the filter septum by recirculating a filter aid slurry. After precoating, small amounts of filter aid (body feed) are regularly added to the liquid to be filtered. As filtering progresses, the filter aid, mixed with the suspended solids from the unfiltered liquid, is deposited on the precoat. Thus, a new filtering surface is continuously formed. The minute filter aid particles provide countless microscopic channels which entrap suspended impurities but allow liquid to pass through, without clogging.

An efficient, economical filter aid must:

- 1) have rigid intricately shaped, porous individual particles.
- 2) form a highly permeable, stable and incompressible cake
- 3) remove even the finest solids at high rates of flow
- 4) be chemically inert and essentially insoluble in the liquid being filtered.



Diatomite meets these requirements due to the wide variety of intricately shaped particles and inert composition which makes it practically insoluble in all but a few liquids.

## THE FILTRATION SYSTEM

The essentials of a filter aid filtration system consist of the filter, the filter feed pump, tanks containing filter aid for precoating and body feed pump for continuous addition of filter aid

Continuous addition of filter aid (body feeding) is accomplished either by feeding filter aid as a slurry or by dry feeding. Slurry feeding is usually done with plunger or diaphragm pumps. If filtration is a batch process, the filter aid can be added directly to the batch as admix.

In the operation of a filtration system, the filter is first precoated by circulating a mixture of filter aid and clear or filtered liquid from the precoat tank through the filter and back to the precoat tank. This is continued until all the filter aid is deposited on the filter septum. The body feed injection system is then started and the filter is changed over, with minimum fluctuations in pressure, from precoating to filtering.

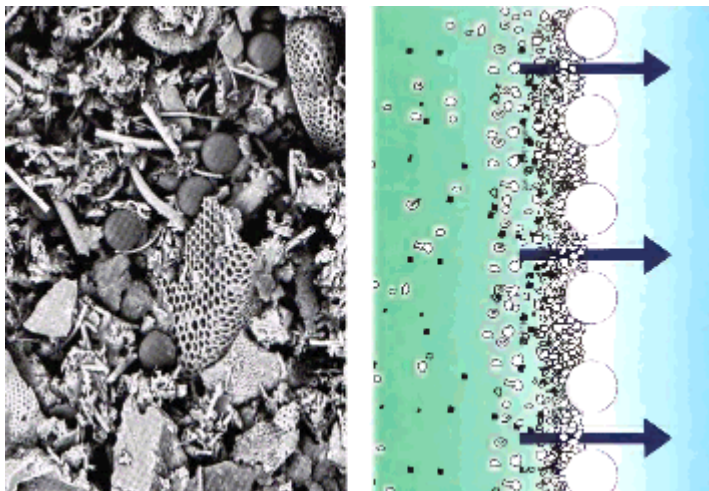

## PRECOATING

The first step in the use of filter aid is to build up a "precoat" of filter aid on the filter septum. The purpose of the precoat is threefold:

1. To prevent the filter septum from becoming clogged by impurities, thus prolonging septum life.
2. To give immediate clarity.
3. To facilitate cleaning of the septum at the end of the cycle.

Precoating is accomplished by circulating a slurry of filter aid and filtered or clear liquid between the filter and the precoat tank. Since most of the filter aid particles are smaller than the openings in the septum, they must form the precoat by bridging these openings. These bridges can be upset by air bubbles, sudden changes in pressure, or vibrations, causing the filtrate to become turbid until the upsetting influences have been corrected.



## AMOUNT OF PRECOAT

The amount of precoat should be from 1 to 2 lbs. of filter aid per 10sq. ft. of filter area, the greater amount being used when distribution of flow in the filter is poor. If it is perfectly distributed, 10 lbs. (4.5 kg) of filter aid per 100 sq. ft. (9.29 sq. m) of filter area will give a precoat of approximately 1/16" (1.6 mm) in thickness. Precoat slurry concentration will depend primarily on the ratio of filter area to the liquid volume of the filter and piping. If the concentration is much below 0.3%, precoating may be difficult since the formation of the bridge depends partly on the "crowding" effect of the particles of Celite trying to get through the septum openings.

Surface of a 7" plate: 0.34 ft<sup>2</sup>

Surface of a 10" plate: 0.69 ft<sup>2</sup>

Surface of a 20" plate: 2.78 ft<sup>2</sup>

Exemple: A 10" press with 6 full plates gives 4.17 ft<sup>2</sup>

So, use about ¾ lbs of filter aid.

1 cup of filter aid = 0.259 lbs

¾ divided by 0.259 = 2.89 so, use 3 cups of filter aid

## PRECOATING RATE

The precoat pumping rate will depend mainly on the viscosity of the liquid used. The rate should be sufficient to keep all the filter aid in suspension but should not be fast enough to cause erosion of precoat in the filter. For water, a typical rate is from 1 to 2 gals. per sq. ft. of filter area per minute (gsfm), or 40-80 liters per sq. m of filter area per minute. For viscous liquids, the rate may be as low as 5 gals. per sq. ft. per hour (gsfh), or 20 liters per sq. m per hour. A general rule for precoating is to precoat at that rate which gives a differential pressure of approximately 2 lbs./sq. in (13.8 kilopascals). For water, an upward velocity of at least 4 1/2 ft./min. (1.4 meters/min.) is required for proper filter aid suspension. The suspension of filter aid can be improved in the tank type, or pressure leaf filter, by recirculating part of the inlet flow from the top of the filter back to the precoat tank.

## TROUBLESHOOTING

Precoating filtrate should clear up in 2 to 5 minutes. However, this does not mean the precoat is all in place. Continue precoating for a few more minutes. Lack of clarity of filtrate could be caused by any precoat erosion caused by too high a circulation rate; blinding of filter septum; insufficient precoat at top of leaves caused by too little circulation; tears in septum; old screens with worn and/or separated wires; leaks between septum and rim of leaf; worn gaskets between leaf discharge nipple and discharge manifold; wrinkles in septum; negative pressure on discharge manifold causing flashing inside the leaf.





## FILTERING CAPACITY

7" press: 0.2 to 0.4 barrels (40 us gallon) per plate.

10" press: 0.4 to 0.75 barrels per plate.

20" press: 1.5 to 3 barrels per plate.

**Note:** those numbers are approximative. Many factors will affect the press performance (syrup temperature, quality of syrup, quantity of niter in the syrup etc.)

## MAINTENANCE

Occasionnaly grease the threads on the filter press rods.

The only other maintenance required for the press is to keep it clean by washing it with hot water.

See the pump manual to see how to maintain it.

## TROUBLESHOOTING

<u>Problem</u>	<u>Solution</u>
Syrup is cloudy	<ul style="list-style-type: none"><li>- Plates are assembled wrong, verify tabs on the plates</li><li>- A paper is blown, replace the papers</li><li>- Not enough filter powder, add more powder</li></ul>
Press stop filtering (no flow)	<ul style="list-style-type: none"><li>- Verify pressure, if above 80 psi, replace papers</li><li>- if pressure is normal, pump problem, repair or replace</li></ul>



# WARRANTY

Your new CDL filter press is covered by limited 2 year warranty against manufacturing defects. For two years from your original date of purchase, Les Équipements d'Érablière CDL (CDL), will replace or replace any parts of this press that prove to be defective in materials or workmanship when such evaporator is installed, used and maintained in accordance with the provided instructions.

## Exclusions

This warranty does not cover the following:

1. Product that has been transferred from its original owner to another party or removed outside the USA or Canada.
2. If anything else than maple syrup is processed in the machine.
3. If the pump is run dry.
4. If normal maintenance is not performed as specified in the CDL owner's manual.
5. Production loss due to any kind of failure of the press.
6. Revenu losses due to syrup quality.
7. Service calls which do not involve malfunction or defect in materials or workmanship, or used other than in accordance with the provided instructions.
8. Service calls to correct the installation of your press or to instruct you how to use it.
9. Any service beyond the first two years.
10. Damages caused by: services performed by unauthorized service companies; use of parts other than genuine CDL parts or parts obtained from persons other than authorized service companies; or external causes such as abuse, misuse, inadequate power supply, accidents, fires, or acts of God.
11. It doesn't cover the consumable products or accessories.
12. If the product was damaged by abusive use, negligence, accident caused by the customer, modification made by the customer, variation in the electric power.
13. Damage cause by the use of products that are not meant for use with our equipment or a bad use of cleaning products.



**Disclaimer of implied warranties; limitation of remedies**

Customer's sole and exclusive remedy under this limited warranty shall be repair or replacement as provided herein. Claims based on implied warranties, including warranties of merchantability or fitness for a particular purpose, are limited to two years or the shortest period allowed by law, but not less than two years. CDL shall not be liable for consequential or incidental damages such as property damages and incidental expenses or loss or revenues caused by any event covered by this warranty. Some states and provinces do not allow the exclusion or limitation of incidental or consequential damages, or limitations on the duration of implied warranties, so these limitations or exclusions may not apply to you. This written warranty gives you specific legal rights. You may also have other rights that vary from states to states.

**If you need service**

Keep your receipt, delivery slip or some other appropriate payment record to establish the warranty period should service be required. If service is performed, it is in your best interest to obtain and keep all receipts. Service under this warranty must be obtained by contacting CDL at the addresses or phone numbers below. Obligations for service and parts under this warranty will be performed by CDL in Canada. Products features or specifications as described or illustrated are subject to change without notice.

Les Équipements d'Érablière CDL  
257 Route 279  
St-Lazare, Québec, Canada  
G0R 3J0  
(418) 883-5158

CDL USA  
3 Lemnah Drive  
St. Albans, VT, 05478  
(802) 527-0000



# CDL's 10" filter press

Note : model may look different, but part numbers remains the same

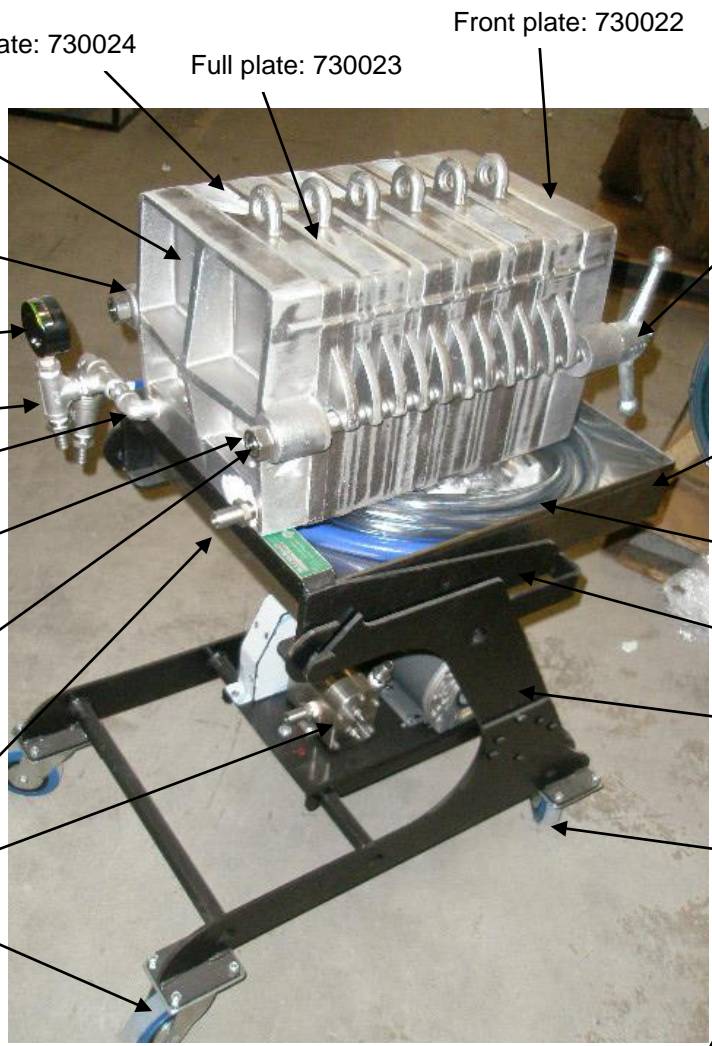

Hollow plate: 730024

Full plate: 730023

Front plate: 730022

Rear plate: 730021

Handles: 666000710

SS washers: 66855522

Pressure gauge: 64010

SS T: 711212

SS pan: 660710

SS street elbow: 60109S05

Clear hose (15'): 6600210

SS nuts: 6660011

Press support: 666010

SS rods std press: 66600010

For long press: 66600010B

For short press: 66600010E

Assembled cart: 66606

SS adaptor: 710563

Wheel with brake: 6074449

Optional 1/2 SS gear pump:

Swivel wheel: 6072449

Guard: 69SPPGA



Small pulley: 669996

Large pulley: 669995

Belt: 661568

Wire and switch: 52135

SS paper guide rods: 660906

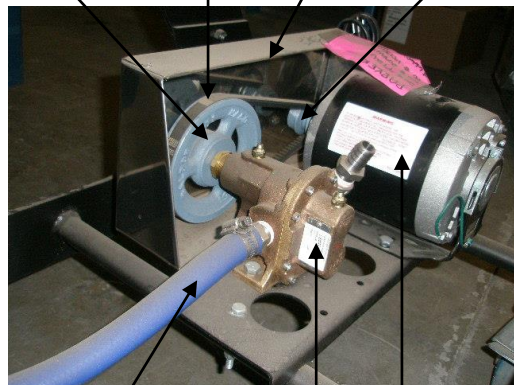

Blue hose (2.5'): 66283

Motor: 66B207

Optional brass gear pump: 664000BR

20

Option diaphragm pump 1/2" :669585

SS outlet: 6601040

Clear hose (15'): 6600210



CDL maple sugaring

# 7" CDL filter press

Front plate: 730026

Hollow plate: 730028

Rear plate: 730025

Handles: 666000710

Full plate: 730027

Pressure gauge: 64011

3/4" Nuts: 6600011

Wire and switch: 52

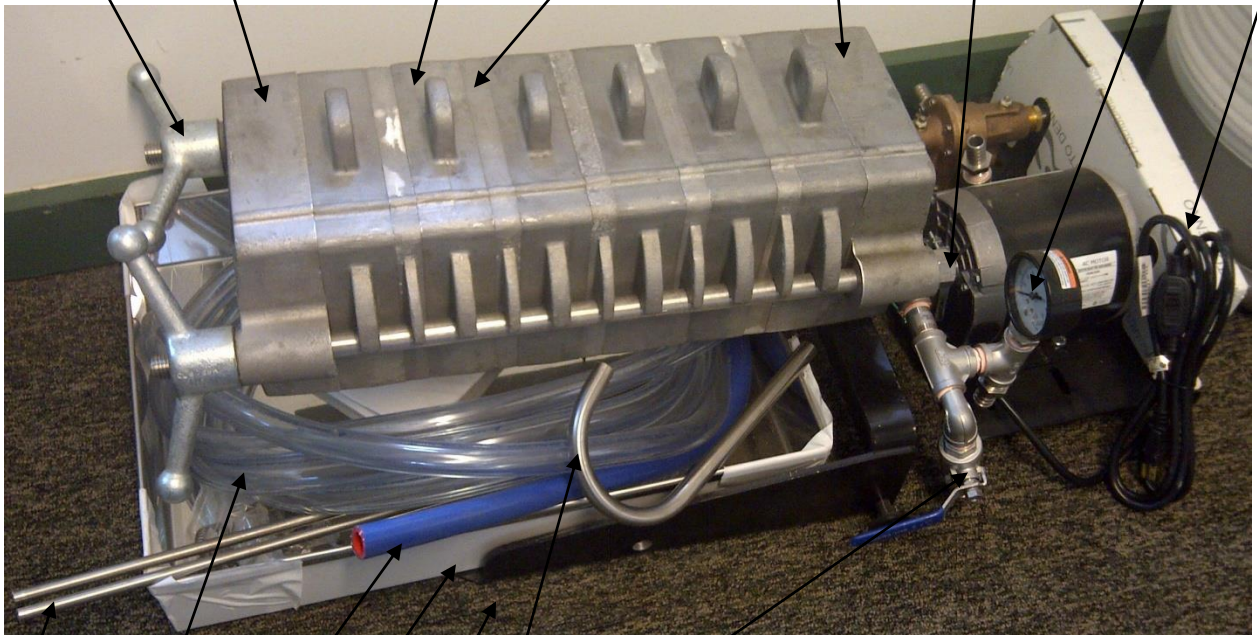

Guide rods: 660910

1/2" ball valve: 601412

Brass gear pump: 664000BR  
Optional SS CDL gear pump: 664000SCDI

Clear hose 5/8": 6600210

Syrup nozzle: 6601040

Blue hose: 66283

Press support: 666010

Drip tray: 660710

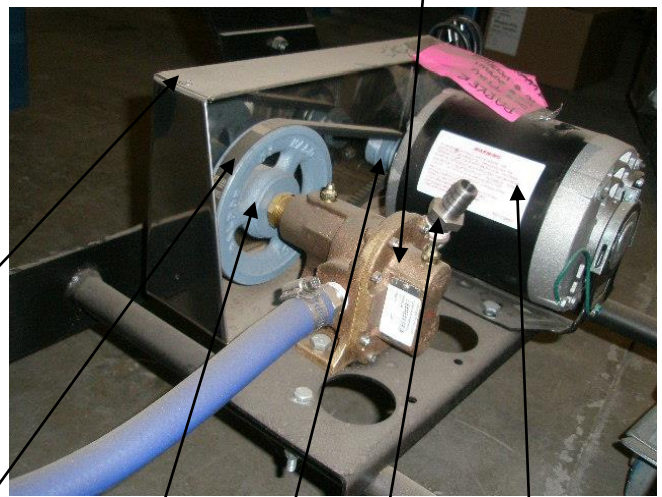

Guard: 69SPPGA

Large pulley: 669995

Motor: 66B207

Belt: 661568

Small pulley: 669996

Adaptor 1/2" x 5/8": 710563

21



Option diaphragm pump 1/2" :669585

