



User Manual

Version 1.0 | 07/04/2025
6601043AS-MAN-EN

DYNAMIC MIXER

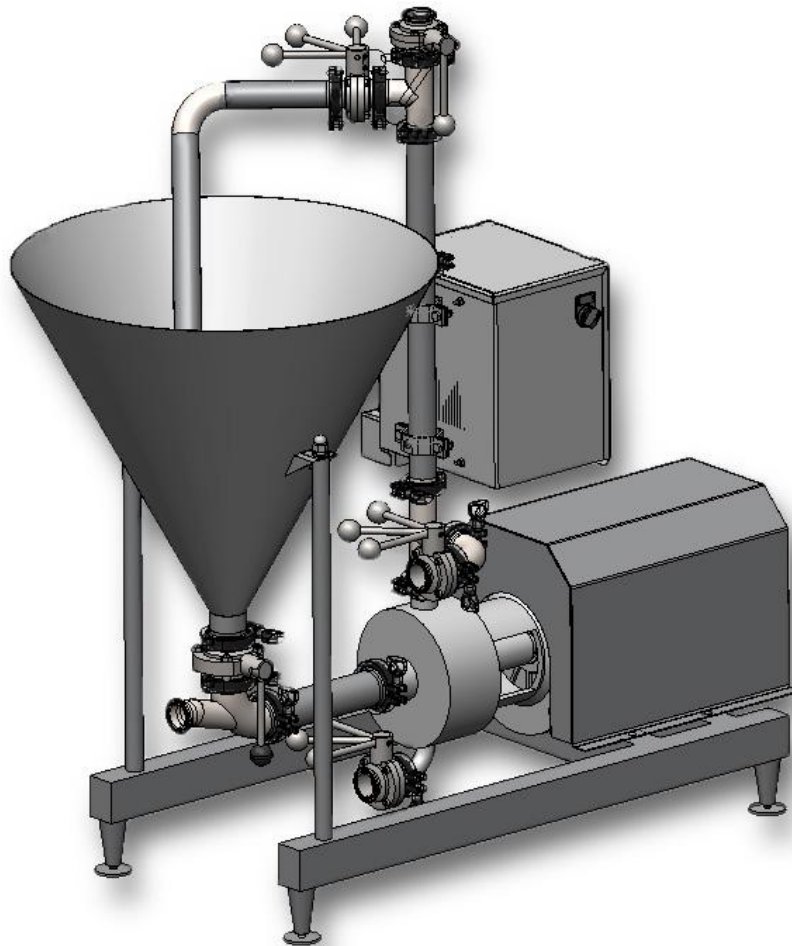

Table of Content

Introduction	4
Safety Instructions	5
Specific Precautions	5
Product description.....	6
Technical Specifications	6
Optional Components	6
Component identification	7
Installation.....	8
Site Preparation	8
Required Tools.....	8
Installation Steps.....	9
Post-Installation Checks	11
Operation	12
Mixer Cleaning Before First Use	12
Loading the Filter Press	13
Incorporating Powder into the Unfiltered Syrup Tank.....	14
Filtering the Insulated Tank Using the Press.....	14
Mixer Desugaring	15
Usage Tips.....	15
Maintenance.....	16
Storage	16
Troubleshooting	16
Warranty	17
Notes.....	19

Introduction

Thank you for choosing the dynamic mixer from CDL Sugaring Equipment. We are proud to offer you high-quality products designed to meet the rigorous demands of the maple industry.

This manual will help you become familiar with your dynamic mixer and guide you in using it according to best practices to maximize its performance. It provides clear and detailed instructions for installation, operation, maintenance, and troubleshooting. Please read it carefully before using the mixer to prevent any damage caused by improper use. We recommend keeping this manual for future reference. It is also available on the CDL website.

At CDL, we are committed to continuous innovation and improvement to provide you with the most efficient and reliable solutions. If you have any questions or concerns, do not hesitate to contact our technical support team — they will be happy to assist you.

Thank you for trusting CDL for your maple equipment needs.

Safety Instructions

Safety is a top priority when installing and using your equipment. This section provides essential information to ensure safe operation.

Please carefully read all safety instructions before starting any operation. The following pictograms are used in this manual to draw your attention to specific hazards and precautions. Understanding and following these instructions will help prevent accidents and ensure a safe working environment.

General Hazard



This symbol indicates a potential risk of serious injury or material damage. Please take all necessary precautions to avoid accidents.

Electrical Hazard



This symbol warns of a risk of electric shock, which can result in serious injury or death. Ensure the power supply is disconnected before performing any intervention and follow electrical safety instructions.

Crushing Hazard



This symbol indicates a potential crushing hazard that could lead to serious injury. Be cautious in areas where moving or heavy parts may shift.

Burn Hazard



This symbol warns of a potential burn risk that could result in serious injury. Pay attention to hot surfaces and high-temperature liquids. Use protective equipment to prevent burns.

Specific Precautions



Burns: Wear protective equipment. Hot syrup may splash.



Crushing hazard: Never insert fingers or objects into the suction piping.



Installation: Use a forklift or lifting device (minimum capacity: 250 lb).

Never turn the package upside down, as the mixer could come loose.

Product description

The CDL dynamic mixer is designed to blend solid particles into a liquid to achieve a homogeneous solution. It ensures effective incorporation of filter aid into the syrup prior to the filtration stage.

It can be used to mix the filter aid directly into the contents of the insulated tank and can even be used to feed your filter press before starting the filtration process.

Technical Specifications

Specification	Detail
Powder tank capacity	50 liters
Electrical power	4,000 W, 3-phase
Electrical consumption	20 A at 240 V
Overall dimensions	48.75" (length) x 37" (height) x 23.75" (width)
Materials in contact with liquids	304 stainless steel (funnel, piping, pump turbine, valve)
Connection size for intake, return, and press feed	1 ½" Tri-Clamp
Connection size for drainage	1" Tri-Clamp

Optional Components

Description	Part Number
1 ½" Glass Sight	6600150
Paddle with Long Handle	674242
1 ½" Butterfly Valve with Ferrule	60T150
Ferrule Clip	60R13HC112
Silicone Gasket	60GASKET112SILI
1 ½" Ferrule Tee	77007715F
1 ½" Ferrule Elbow	770063

Component identification

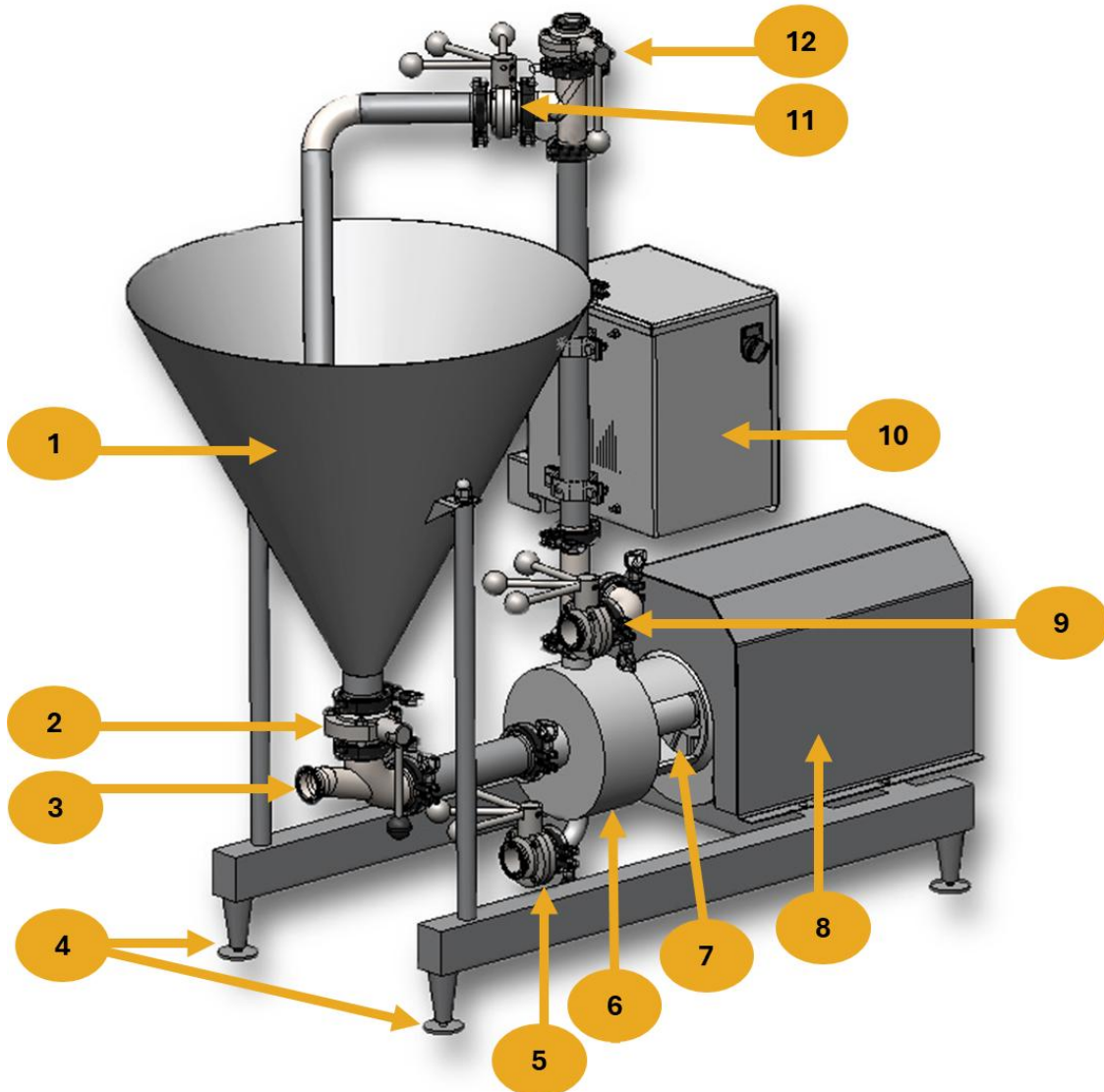

#	Component
1	Funnel
2	Suction Valve
3	Mixer Feed
4	Adjustable Legs (x4)
5	Drain Valve
6	Impeller
7	Water Inlet and Outlet for Mechanical Seal
8	Electric Motor and Protective Cover
9	Outlet Valve for Press Loading
10	Electrical Enclosure
11	Recirculation Valve
12	Return-to-Tank Valve





Installation

Site Preparation

Before installation, choose an appropriate location for the dynamic mixer:

- Install the unit in close proximity to your unfiltered hot syrup tank.
- Ensure there is sufficient clearance around the mixer to allow for easy movement and filter powder filling.
- Make sure the installation site includes:
 - access to potable water,
 - a functional drain for discharging water from the mechanical seal.

Required Tools

Wrench for adjusting the height of the legs	
Teflon Tape	
Multi-grip pliers	
Cutter pliers	

Installation Steps

Refer to the assembly diagram below to visualize a typical installation.

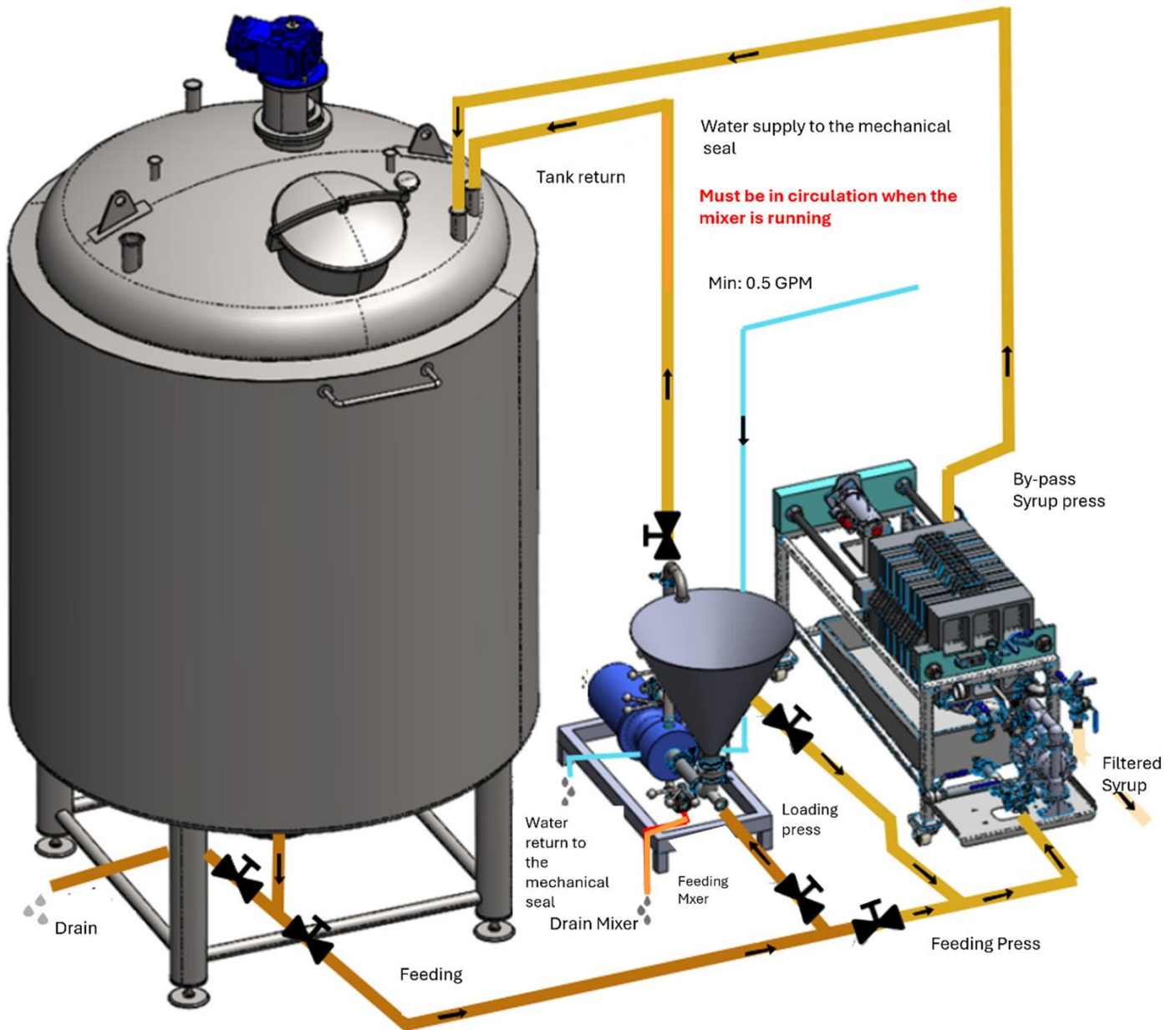

1. Positioning

- Place the dynamic mixer close to the unfiltered syrup tank.
- Adjust the legs to properly level the equipment.

Important: The syrup inlet on the mixer must be at the same height or lower than the tank outlet. The mixer is not self-priming.

2. Plumbing Connections

Connect the syrup lines using Tri-Clamp fittings:

- Syrup inlet to mixer (3)
- Return line from mixer to insulated tank (12)
- Mixer outlet to syrup press (9)
- Pump drain (5)

Recommendation: Use stainless steel hoses for durability.

Best Practice: Add glass sight gauges to confirm fluid circulation and prevent valve handling errors (e.g., drain valve left open).

3. Electrical Connection

Important: This connection must be carried out by a certified electrician.

- Power the mixer according to electrical specifications: 240 V / 1-phase / 20 A.

4. Potable Water Connection (Min. 0.5 GPM)

- Connect the water inlet to a pressurized potable water source. (The mixer is equipped with a garden hose adapter.)
- Connect the water outlet to the drain
- Keep the water supply tap or hose open at all times
- The electric valve opens automatically when the variable speed drive is activated and closes when it is turned off
- This automation ensures water is used only while the mixer is running

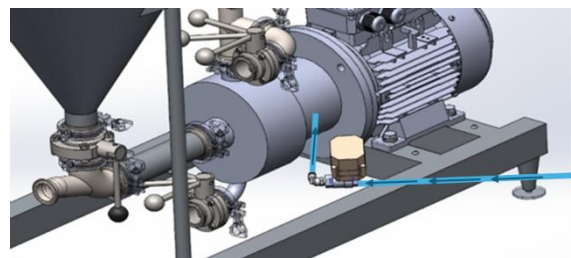
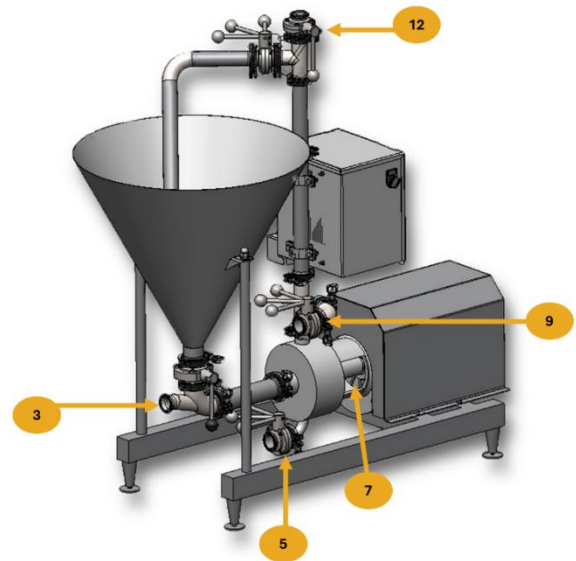

Post-Installation Checks

- The syrup inlet on the mixer is at the same level or lower than the tank outlet.
- An inlet valve is installed to prevent syrup backflow by gravity when the unit is off.
- A continuous potable water supply is properly connected and functional to lubricate the mechanical seal.
- No fittings or sight glasses are left open or improperly secured.
- The mixer is stable, properly leveled, and accessible for operation.

Operation

Mixer Cleaning Before First Use

Before initial operation, it is essential to clean the mixer to remove any potential contaminants:

1. Prepare a solution of hot soapy water.
Add:
 - **1 cup (250 ml) of vinegar** or
 - **15 ml (½ oz) of peracetic acid per gallon (4 L) of solution.**
2. Fill the funnel (1) to approximately **75% capacity** with the solution.
3. **Open the suction valve (2) and the recirculation valve (11).**
4. **Close all other valves** to create a recirculation loop.
5. Start the mixer using the **variable speed drive** and circulate the solution for **5 minutes.**
6. Stop the mixer and **open the drain valve (5)** to empty the contents.
7. Close the drain valve (5), then fill the funnel with clean water.
8. Restart the mixer to perform a **rinse cycle.**
9. Repeat rinsing until all traces of cleaning solution are completely removed.

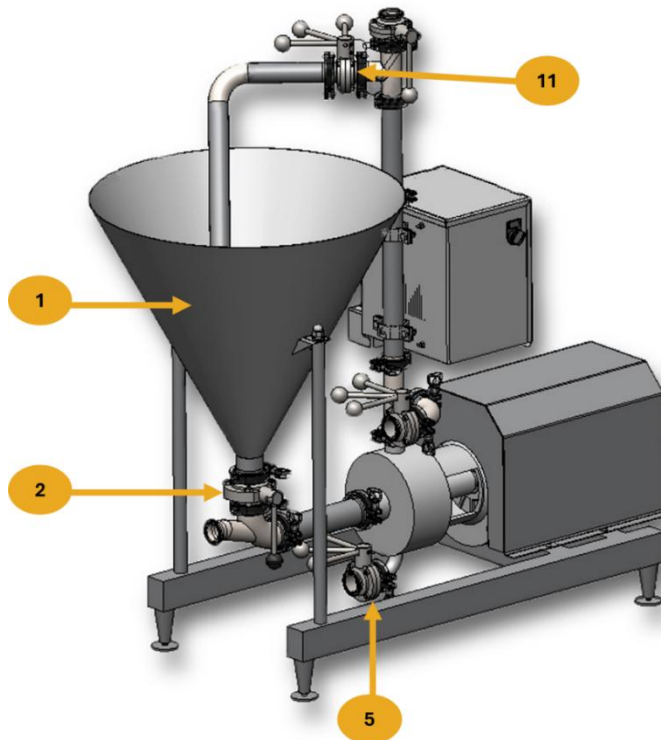

Loading the Filter Press

- Close the following valves:
 - Mixer feed (3)
 - Press feed (on the filter press)
 - Return to tank (12)
 - Press loading (9)
 - Mixer drain (5)
- Open the **suction valve (2)**, then the **feed valve (3)** to fill the **funnel (1)** by gravity to **approximately 75%** of its capacity. Then close the feed valve (3).
- Open the **recirculation valve (11)** and start the mixer. Position the recirculation hose at an angle to create a **vortex**, which helps incorporate the filter powder without splashing.
- Add the **appropriate amount of filter powder**, based on the press capacity, into the center of the vortex. Let the mixer run for a few seconds.
- Open the **bypass valve (on the press)** and the **filtered syrup outlet valve** (on the press).
- Gradually open the **press loading valve (9)**. Let the mixer run until the funnel is fully emptied.
- Stop the mixer.

Note: Depending on the size of your filter press, you may need to repeat the loading steps. A press that is 15 inches or larger will require more than one funnel to be properly filled. After one or more loadings, filtered syrup should begin to come out of your press.

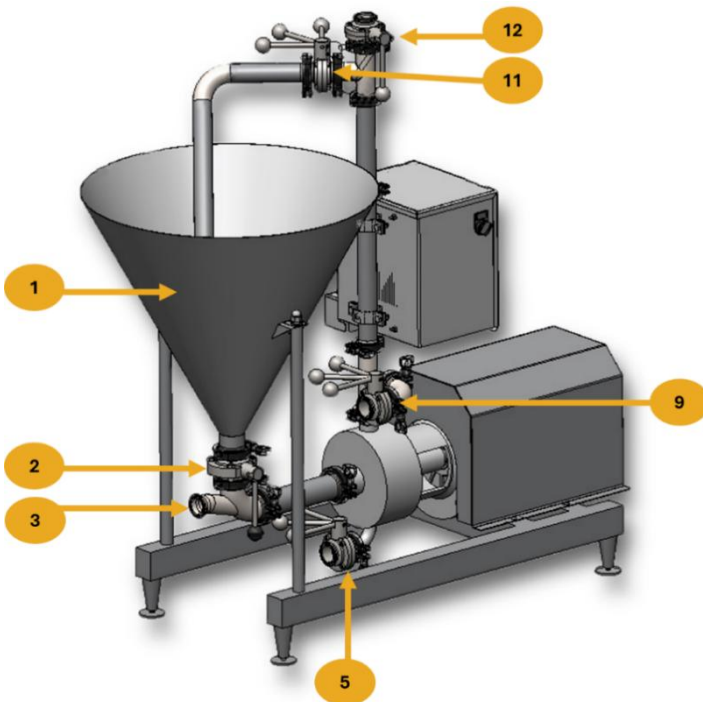

Incorporating Powder into the Unfiltered Syrup Tank

1. Close all valves (same as in the previous step).
2. Open the **funnel suction valve (2)** and the **mixer feed valve (3)** until the funnel is filled to approximately 75%. Then close the feed valve.
3. Open the **recirculation valve (11)** and start the mixer.
4. Add the **filter powder** into the center of the vortex.
5. Open the **return-to-tank valve (12)** and let the mixer run until the funnel is fully emptied.
6. Stop the mixer.

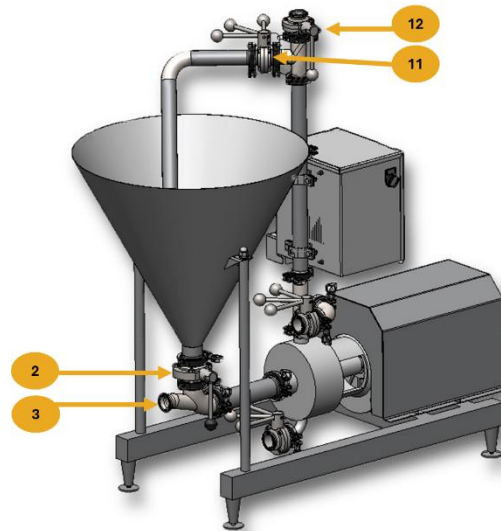

Note: Repeat the process according to the amount of syrup to be reprocessed. Keep the insulated tank's agitator running to maintain the powder in suspension.

Filtering the Insulated Tank Using the Press

1. Close the following valves:
 - Mixer feed (3)
 - Return to tank (12)
 - Press loading (9)
 - Mixer drain (5)
2. Fully open:
 - The press **bypass valve**
 - The **filtered syrup outlet valve** (on the press)
3. Open the press **feed valve** as well as the tank feed line.
4. Start the **press pump** and proceed with filtration.
5. When the flow rate decreases:
 - Gradually close the bypass valve.
 - When the flow becomes very low, disassemble, clean, and reassemble the press with new filter papers to continue.

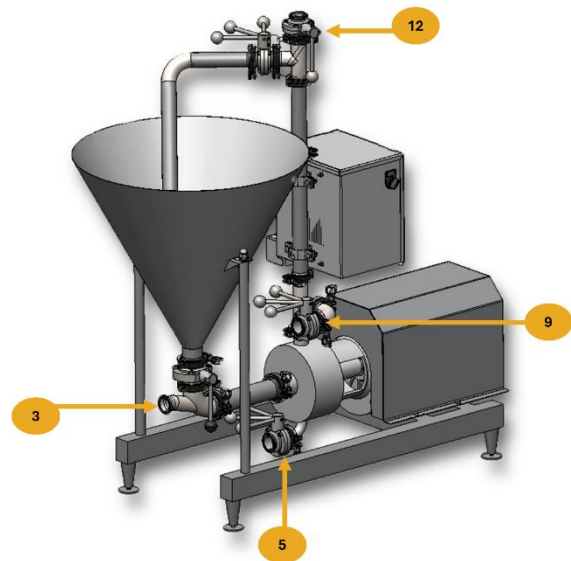

Mixer Desugaring

1. Close all valves (including the drain).
2. Start the permeate **pump to feed** the syrup **tank's spray balls**.
 - Keep the tank agitator running during this step.
3. Open the following valves:
 - Tank feed
 - Mixer feed (3)
 - Mixer recirculation (11)

Then, start the mixer to fill the funnel to approximately 75%, stop the mixer, and close the feed valve (3).

4. Open the **funnel suction valve (2)** and restart the mixer to circulate the permeate.
5. Open the **return-to-tank valve (12)** and close the recirculation valve (11). The sweet permeate flows back to the tank.
6. Open the **press feed valve** and start the pump to desugar the press.

Repeat as needed until the Brix reading at the outlet is nearly zero.



WARNING – Tank Implosion Risk

When adding cold permeate to a tank containing hot unfiltered syrup, significant air displacement occurs.

Ensure the tank is equipped with proper air intake.

Usage Tips

- Do not overload the funnel with powder. Leave enough space to allow syrup suction.
- Quickly transfer syrup to the press or tank to keep it hot. Hot syrup filters more efficiently and preserves better.

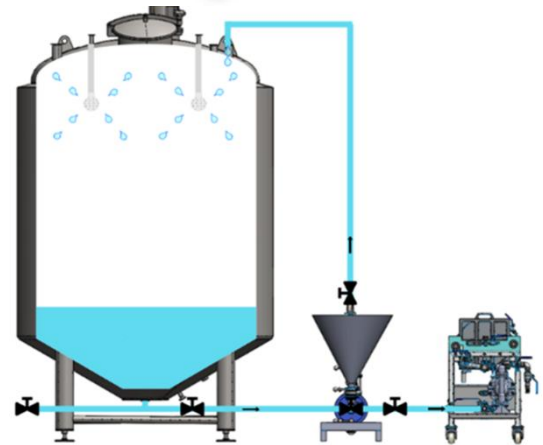
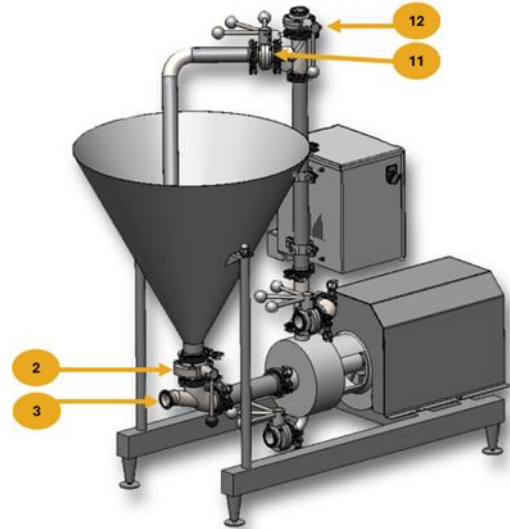

Maintenance

At the beginning and end of the season, thoroughly clean and disinfect the mixer to prevent bacterial growth.

- Use a solution of **permeate + ½ cup of peracetic acid (Oxysan #66298)**.
- Fill the funnel (1) to three-quarters and circulate the solution in a loop for a few minutes.
- Rinse with clean water or permeate until all traces of acid are removed.
- **Open the drain valve (5)** to fully empty the equipment.

Storage

- **Always drain** the mixer before storage.
- **Do not expose the equipment to freezing temperatures**, as this may damage the pump.
- Tilt the unit if needed to ensure all water is fully drained.

Troubleshooting

Most Common Issue	Solution
The mixer won't draw from the funnel	The mixture is too thick. Dilute the syrup.
The mixer does not start	Check the water pressure at the mechanical seal. Without water supply, the mixer will not start.

Warranty

CDL dynamic mixers are covered by a limited two-year warranty (equivalent to two consecutive sugaring seasons). For two years from the original date of purchase, Les Équipements d'érablière CDL Inc. will repair or replace parts found to be defective in materials or workmanship, provided the equipment has been installed, used, and maintained in accordance with the instructions in the user manual.

Exclusions

This warranty does not cover the following:

- Products whose original serial number has been removed, altered, or is not clearly legible.
- Equipment that has changed ownership or is located outside North America.
- Damage caused by storing the mixer in freezing conditions.
- Failure to follow CDL's maintenance procedures.
- Starting the pump dry (without liquid inside).
- Production losses related to mixer malfunctions.
- Revenue losses resulting from syrup quality issues.
- Service calls not related to defects in manufacturing or operation, or for equipment used outside the provided instructions.
- Service calls intended solely to verify installation or provide usage instructions.
- Service calls made after the two-year warranty period.
- Damage caused by: unauthorized repairs; the use of non-original CDL parts or parts not obtained through an authorized technician; or external causes such as abuse, misuse, accidents, fires, or natural disasters.
- Consumables such as filter powder.
- Damage resulting from misuse, negligence, customer modifications, or electrical issues.
- Damage caused by using incompatible products or improper cleaning agents.
- Warranty coverage for electric motors is subject to approval by the CDL Service Department.
- Any electrical or electronic component powered by a generator is not covered.
- Damage caused by voltage fluctuations is not covered.

Warranty Disclaimer & Limitations of Remedies

The customer's sole remedy under this limited warranty is repair or replacement of the product as described above. Claims based on warranties, including merchantability or fitness for a particular purpose, are limited to two years or the shortest period allowed by law, which must not be less than two years. Les Équipements d'érablière CDL Inc. is not liable for incidental or indirect damages, including material and implied damages. Some states and provinces do not allow restrictions or exemptions on incidental or indirect damages, nor limitations on warranties. In such cases, these limitations may not apply. This written warranty grants you specific legal rights. Depending on your state or province, you may have additional rights.

If You Need Repair Service

Keep your receipt, delivery slip, or any valid proof of payment to establish the warranty period in case repair service is required. If a repair is performed, it is in your best interest to obtain and keep all receipts. To obtain service under this warranty, contact CDL using the addresses or phone numbers listed below.

Specifications and features described or illustrated may be subject to change without notice.

CDL Sugaring Equipment Inc.

257, route 279
Saint-Lazare-de-Bellechasse (Québec) G0R 3J0
Canada
418 883-5158 | 1 800 361-5158
cdlinc.ca

CDL USA

3 Lemnah Drive
St. Albans VT 05478
United States
802-527-0000 | 1-800-762-5587
cdlusa.com

